

S I M E S

**CASSAFORMA MARKER/WALKER
MARKER/WALKER RECESS BOX**

ISTRUZIONI DI MONTAGGIO, USO, MANUTENZIONE E SMALTIMENTO
INSTALLATION, USE AND MAINTENANCE AND WASTE MANAGEMENT INSTRUCTIONS
NOTICE DE MONTAGE, UTILISATION, ENTRETIEN ET ÉCOULEMENT

S.6329

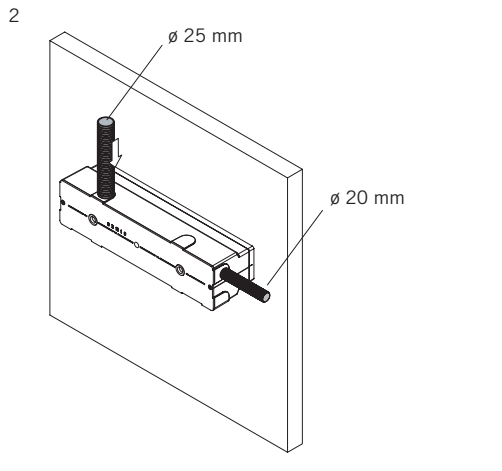
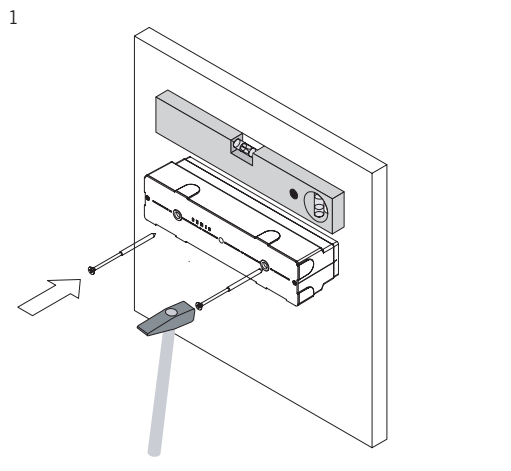
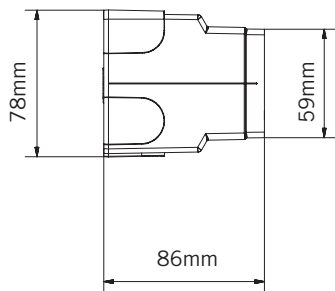
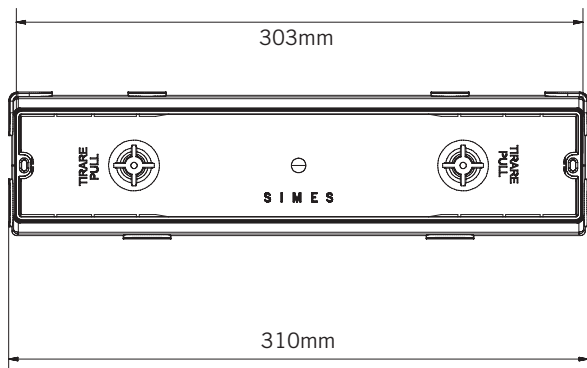
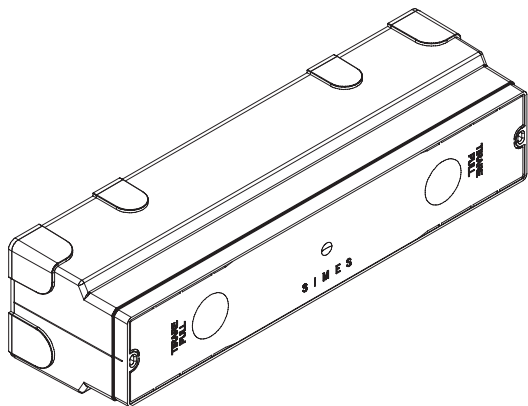

3

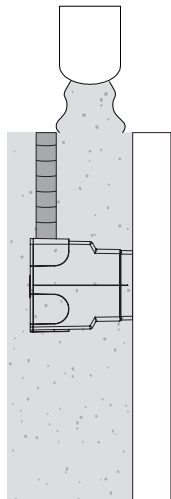

4

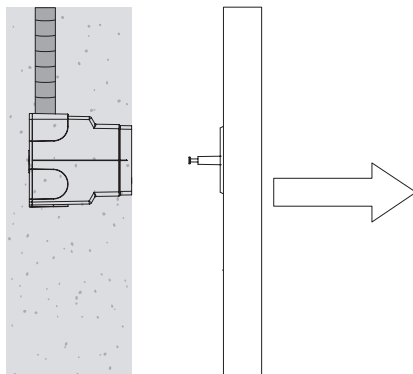

5

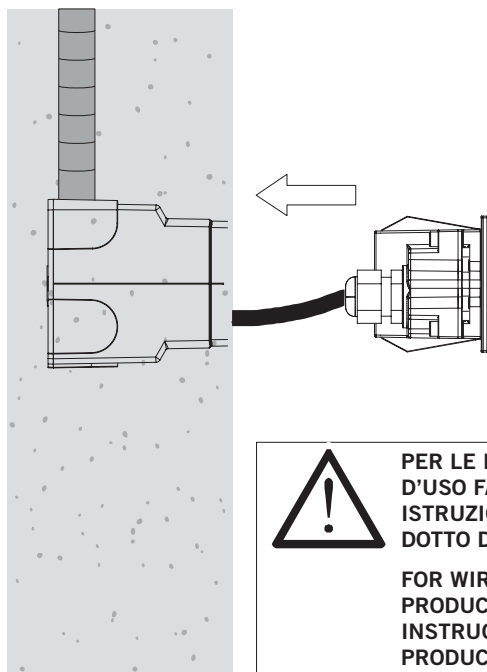

PER LE ISTRUZIONI DI CABLAGGIO ED INDICAZIONI
D'USO FARE RIFERIMENTO ALLE RELATIVE
ISTRUZIONI DI MONTAGGIO INCLUSE CON IL PRO-
DOTTO DELLA SERIE MARKER/WALKER ACQUISTATO.

FOR WIRING AND INDICATION ABOUT THE
PRODUCT PLEASE REFER TO THE MOUNTING
INSTRUCTION ANNEXED WITH THE MARKER/WALKER
PRODUCTS.



SIMES S.p.A. VIA G. PASTORE 2/4 - 25040 CORTE FRANCA (BRESCIA) - ITALY
TEL. +39 0309860430 - FAX +39 0309860439
E-mail: simes@simes.it - <http://www.simes.it>

We reserve the right to change specifications without prior written notice